

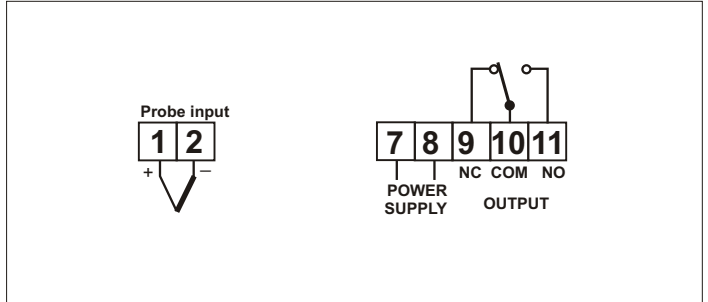

Wiring Diagram



Description

The KLT11BB is designed for many heating and cooling, high temperature applications. The probe temperature is displayed on the bright 3-digit display. The user is able to program 18 different parameters including set point, hysteresis, cycle time and ambient probe adjustment using the silicone front keypad. The unit features error or alarm warning, internal buzzer and password protection. Select between thermocouple J, K or S type, temperature display in °C or °F and 115Vac, 230Vac, 24Vac/dc or 12Vac/dc power supplies.

Model references

The model reference is given by: KLT11BB - WXYZ

Where each suffix can take the following values:

W	Thermocouple Type	J, K, S
X	Display Color	R=Red, G=Green, B=Blue
Y	Supply Voltage	230=230Vac, 115=115Vac 24=24Vac/dc, 12=12Vac/dc
Z	Units	C=°C, F=°F

Installation

NOTE: Unit must be mounted away from vibration, impacts, water and corrosive gases.

- Cut hole in panel 71 x 29 mm (2.80 x 1.14 inches)
- Apply silicone (or rubber gasket) around the perimeter of the hole to prevent leakage.
- Insert unit into hole of panel.
- Slide removable fitting clips onto unit from the back until secure to panel.
- Remove back cover to wire unit
- Wiring diagram is displayed on the top of the unit
- **Note: DO NOT INSTALL PROBE CABLE NEAR POWER CABLES.**
- Replace cover once wiring is completed.

Technical Data

Supply voltages

115Vac±10%, 230Vac±10%, 24Vac/dc±10%,
12Vac/dc±10%

Supply powers

4VAC (230V)

Storage temperature

-20°C to 80°C (-4 to 176°F)

Operating temperature

0°C to 70°C (32 to 158°F)

Probe range

0°C to 700°C (32 to 999°F) for thermocouple J
0°C to 999°C (32 to 999°F) for thermocouple K,S

Accuracy

Better than 1% of full scale

Resolution

1° (3 digits)

Display

3-digit and sign (red, green or blue)

Input

Thermocouple (types J, K or S)

Output

SPDT Relay Resistive load 16A
1HP 240Vac -- 10FLA, 60LRA 240Vac

Dimensions

76 x 34 x 60 mm (3 x 1.34 x 2.36 inch)

Front Protection

IP64

Electrónica Keld, S.L.
Pol.Ind. Empresarium. C/Lentisco, 15
50720 - La Cartuja Baja, ZARAGOZA
Spain

Phone: +34 976 429 099
Fax: +34 976 593 532
E-mail: keld@keld.es
Web: <http://www.keld.es>

List of parameters

	Description	Units	Range
SP	Set Point	Degrees	r1 to r2
r0	Differential or hysteresis	Degrees	1 to 99
r1	Lower value for SP	Degrees	0 to r2
r2	Higher value for SP	Degrees	r1 to 999
d0	Cooling or heating control	Option	Co/Ht
c0	Minimum stopping time	Seconds	0 to 999
c2	Output status with probe error	Range	On/Of
P1	Ambient probe adjustment	Degrees	-30 to 30
P5	Ambient probe type	Range	tcJ,tch,tcS
H5	Access code to parameters	Numeric	0 to 255
A0	Alarm 1 hysteresis	Degrees	1 to 999
A1	Alarm 1 threshold	Degrees	0 to 999
A2	Alarm 1 exclusion time	Seconds	0 to 999
A3	Alarm 1 type	Range	OFF,HI,LO
A4	Alarm 2 hysteresis	Degrees	1 to 999
A5	Alarm 2 threshold	Degrees	0 to 999
A6	Alarm 2 exclusion time	Seconds	0 to 999
A7	Alarm 2 type	Range	OFF,HI,LO

Parameter descriptions

SP = Set point. Temperature we wish to regulate the machine (variable from r1 to r2)

r0 = Differential or hysteresis

r1 = Lower value for SP

r2 = Higher value for SP

d0 = Cooling or heating control

If d0 = Ht and TS is the temperature of ambient probe:

If $TS \geq SP$ the load is disconnected

If $TS \leq SP - r0$ the load is connected

if d0=Co then:

If $TS \leq SP$ the load is disconnected

If $TS \geq SP + r0$ the load is connected

c0 = Minimum stopping time of the load

c2 = Output status with probe error

P1 = Ambient probe adjustment

P5 = Ambient probe type

P2=tcJ (J type), P2=tch (K type), P2=tcS (S type)

H5 = Access code to parameters (it is set to 00 from factory)

A0, A1, A2, A3 = Alarm 1 parameters

If A3=OFF alarm 1 disabled

If A3=HI then a high-temperature alarm is set:

if $TS \geq SP + A1$ the alarm 1 is activated

if $TS \leq SP + A1 - A0$ the alarm 1 is de-activated

If A3=LO then a low-temperature alarm is set:

if $TS \leq SP - A1$ the alarm 1 is activated

if $TS \geq SP - A1 + A0$ the alarm 1 is de-activated

The alarm 1 is not activated until the time since instrument is turn on is higher than A2

A4, A5, A6, A7 = Alarm 2 parameters (similar to alarm 1)

Parameter programming

Set Point (SP) is the only parameter the user can access without code protection.

• Press SET. SP text will appear on the display.

• Press SET again. The real value is shown on the display.

• The value can be modified with the UP and DOWN arrows.

• Press SET to enter any new values.

• Press SET and DOWN at the same time to quit programming or wait one minute and the display will automatically exit programming mode.

Access to all code protected parameters.

• Press SET for 8 seconds. The access code value 00 is shown on the display (unit comes with code set at 00 from factory).

• With the UP and DOWN arrows, code can be set to user needs.

• Press SET to enter the code. If the code is correct, the first parameter label is shown on the display (SP).

• Move to the desired parameter with the UP and DOWN Keys.

• Press SET to view the value on the display.

• The value can be modified with the UP and DOWN arrows.

• Press SET to enter the value and exit.

• Repeat until all necessary parameters are modified.

• Press SET and DOWN at the same time to quit programming or wait one minute and the display will automatically exit programming mode.

**The keyboard code can be reset to ZERO by turning off the controller and turning it on again while keeping the SET key depressed.*

Led indication, buzzer and display messages

The led **OUT** indicates if the load is connected or not.

In normal operation, the probe temperature will be shown on the display. In case of alarm or error, the following messages can be shown:

• Er = Memory Error

• oo = Open Probe Error

• -- = Ambient temperature out of range

In case of alarm or error the internal buzzer is activated. The buzzer can be silenced pressing the SET and DOWN arrows at the same time (when a new alarm or error occurs the buzzer sounds again).

Maintenance, cleaning and repair

After final installation of the unit, no routine maintenance is required.

Clean the surface of the display controller with a soft and damp cloth. Never use abrasive detergents, petrol, alcohol or solvents.

All repairs must be made by authorised personnel.

Electrónica Keld, S.L.
Pol.Ind. Empresarium. C/Lentisco, 15
50720 - La Cartuja Baja, ZARAGOZA
Spain

Phone: +34 976 429 099

Fax: +34 976 593 532

E-mail: keld@keld.es

Web: <http://www.keld.es>